

MR-E-2 OEM Version Rev. 2

The MR-E-2 is a fully integrated driving solution for the Optotune MR-series beam steering mirrors. It provides access to the full functionality of the mirrors, including open and closed loop control.



Main features:

- Graphic user interface *Optotune Cockpit* for control via USB
- Communication interfaces:
 - USB, UART
 - SPI
 - Analog input (± 5 V)
 - Low-level
- Software SDKs for Python and C# available
- RoHS, REACH and CE certified

Mechanical specifications

Dimensions carrier board (L x W)	109 x 77	mm
Dimensions proxy board (L x W)	30 x 30	mm
Dimensions CPU board	31.5 x 29	mm
USB connector	Micro B	
Accepted DC Barrel Plug	2.1 I.D. x 5.5 O.D. x 10.0	mm
Cable length	1	m
Cable diameter	4.5	mm

Analogue input

Voltage range	-5 to +5	V
Resolution	12	bit
Sampling rate	10	kHz

Electrical specifications

Supply voltage range	15 to 28	Vdc
Total power consumption (max)	12	W
SPI logic level (CMOS)	3.3	V
CPU board supply voltage range (only required if custom carrier board used)	4.5 to 17	Vdc

Thermal specifications

Storage temperature	-40 to +85	°C
Operating temperature	0 to 40	°C

Current output stage

Current source type	linear	
Number of channels	2	
DAC resolution	12	bit
DAC sampling rate	10	kHz
DC current	500	mA
Peak current	700	mA

Position readout

Number of channels		4	
Resolution		14	Bit
Sampling rate (on RTI)		58	kHz
Latency (on RTI)		7.5	µs
Position readout jitter (on RTI)		±5	ns
Position readout jitter (other interfaces)		±50	µs
Control loop frequency		10	kHz
Controller dead-time		0.4	ms

Mechanical Layout and Features

Carrier Board

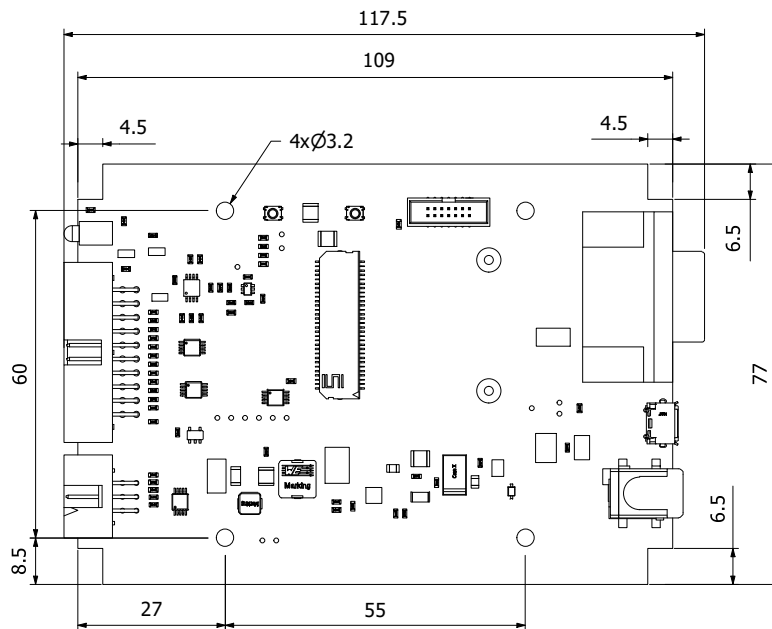

Optotune provides full schematics and manufacturing data for the carrier board on request. For further information, please contact sales@optotune.com.

CPU Board

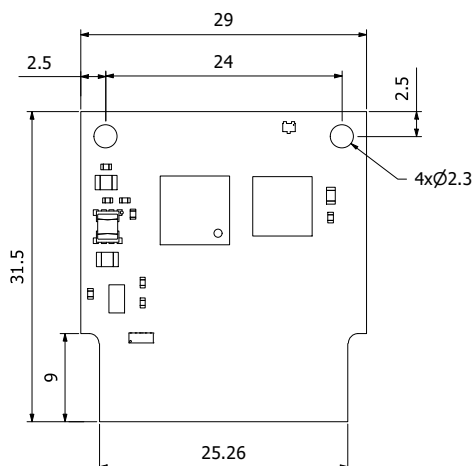

Proxy Board

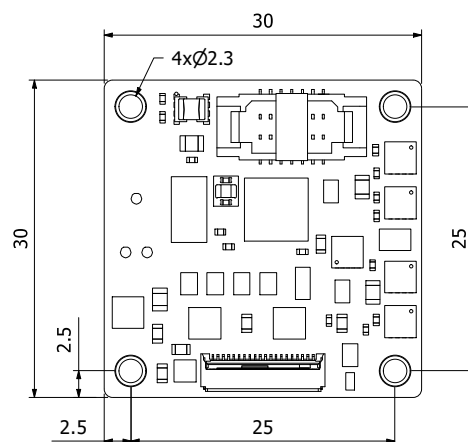

Assembly and Connector Block Diagram

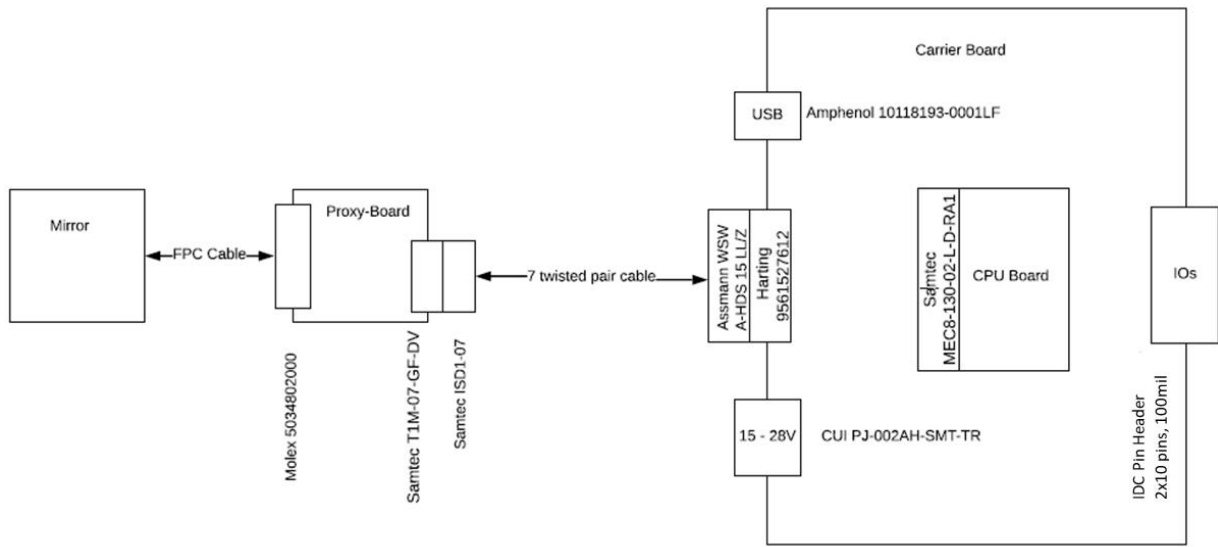

 Do not connect FPC cable upside down. Orientation must be as shown. Wrong orientation will result in permanent damage!

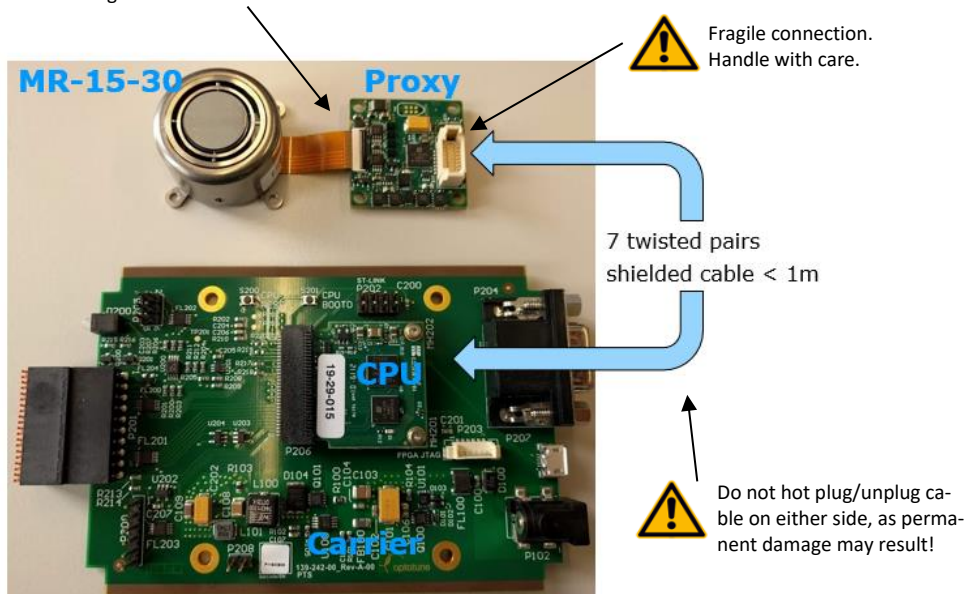

Cable extensions tests:

- FPC cable extension up to 1 m tested. Sensor noise increases gradually.
- Cable (shielded twisted pairs) extension up to 5 m tested.

Pinout (IO and RTI connectors)

The RTI is a Low-Voltage Differential Signaling (LVDS) interface for position readout with low temporal jitter. The interface requires an FPGA to read low-level sensor signals. The RTI is intended for applications requiring dense point clouds at high scan speed such as in LiDAR. A detailed description is available on request.

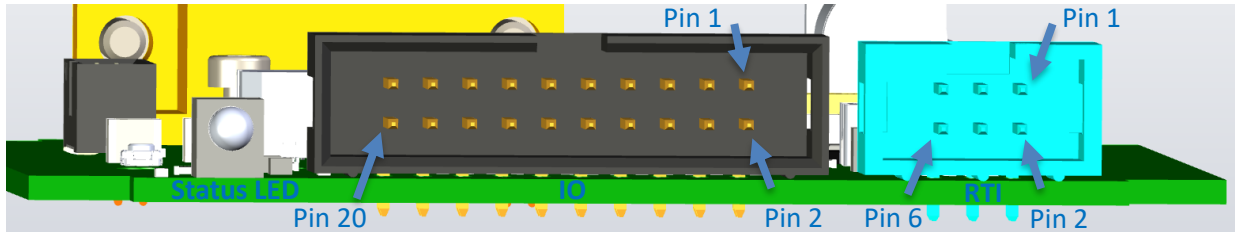

Pin# on I/O Connector	Signal	Description
1	UART_RX	UART Receive line
2	GND	Circuit ground
3	ERROR	Indicates an active error
4	UART_TX	UART Transmit line
5	-	Reserved
6	TRIGGER	Trigger input ¹
7	-	Reserved
8	STABILITY	Mirror not stable ²
9	-	Reserved
10	-	Reserved
11	GND	Circuit ground
12	SPI_DATA_NRDY	SPI Data Not Ready
13	SPI_NSS	SPI Negative Slave Select
14	SPI_MISO	SPI Master Input Slave Output
15	SPI_MOSI	SPI Master Output Slave Input
16	SPI_CLK	SPI Clock
17	GND	Circuit ground
18	GND	Circuit ground
19	AI_X	Analog Input X axis
20	AI_Y	Analog Input for Y axis

Pin# on RTI Connector	Signal	Description
1	-	Reserved
2	CS_SYNC	PD readout trigger (ADC chip select)
3	SCLK_LVDS	Clock
4	FSI	Frame start
5	MISO	Data line (one way only)
6	GND	Ground

¹ Trigger input for 3.3 V CMOS logics to synchronize signal generator or vector pattern unit with external signal.

² According to user defined stability criterion. See Firmware manual.

CPU ↔ Proxy Serial Link

Serial link runs at 38 MHz, 3 LVDS pairs per direction, power and ground to proxy.

Proxy sends status to CPU:

- 4 photodiode ADCs readout (4 x 14 bits)
- 2 temperature sensors (2 x 8 bits)
- EEPROM read followed by data valid flag (8 + 1 bits)
- EEPROM write status (8 bits)

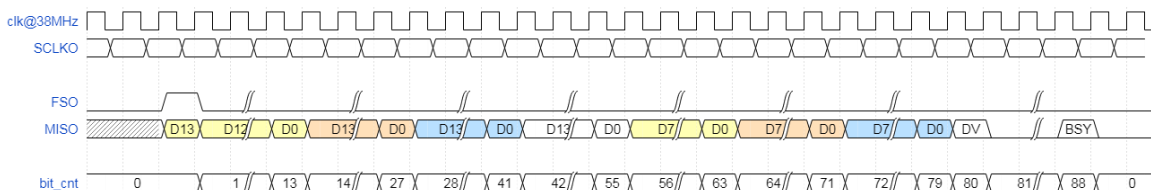
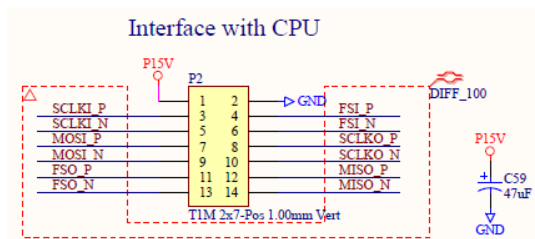

CPU sends commands to proxy:

- Set X and Y drive current values (write to DAC)
- Set IR LED current (write to DAC)
- Enable EEPROM dump
- Control proxy red LED
- Write to EEPROM

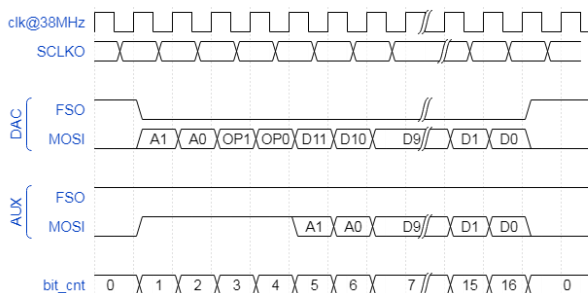

The input/output relations between the proxy and CPU are specified in the table below.

Signal Name (Proxy Board)	Proxy Board	CPU Board
SCLKI	input	output
MOSI	input	output
FSO	output	input
FSI	input	output
SCLKO	output	input
MISO	output	input

CPU Interface with Carrier

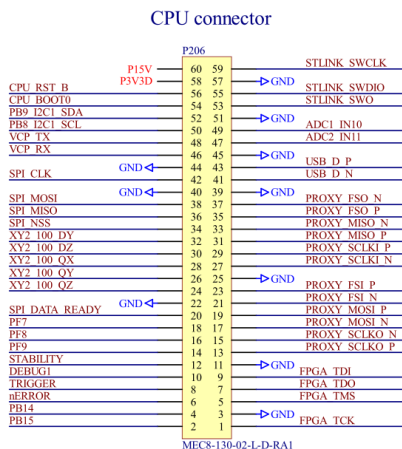

Thermal management

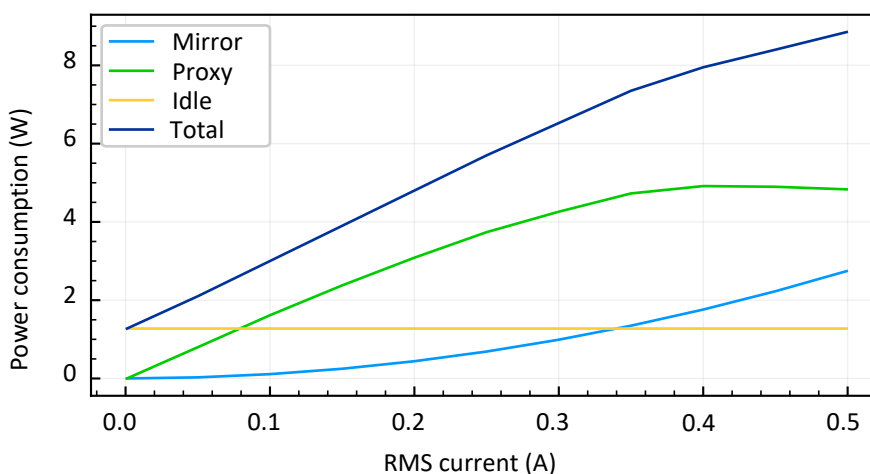

Figure 1: Power consumption dependencies for different parts of the device.

MR-15-30:

- Heat is generated as a function of actuation current (see blue curve in Figure 1) and conducted away through the backside
- Mount mirror firmly on a heat-conductive plate (copper or aluminum)
- Maximum dissipated power at max. static deflection is 0.25 W/channel (0.5 W total)
- For fast oscillations with high duty cycle the dissipated power is 4-5 W for the two axes combined
- Max. operating temperature is 85 °C

MR-E-2 Proxy Board:

- Maximum dissipated power at max. static deflection is 2W/channel (4W total), see green curve in Figure 1
- Maximum operating temperature is 85 °C
- Capability of the heatsink always depends on the maximum specified ambient temperature and the maximum allowed operating temperature of the device
- If we have 4 Watts that need to be dissipated and an ambient temperature of 45 °C, then the heatsink must have at least 10 °C/W thermal resistance so that Proxy Board operates at its absolute maximum limit which is 85 °C (Maximum power dissipation = Difference in temperature / thermal resistance)

- The heatsink should be designed to have a reasonable margin and the Proxy Board should not be operated at the absolute maximum rating, the components circled red (Figure 2) need to be cooled.

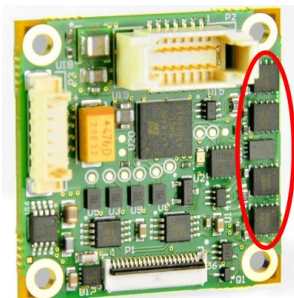

Figure 2: Proxy Board detail.

Overview of Available Standard Products

Standard Product	Mirror type included	Components included
MR-E-2 OEM version Rev. 2	N/A	MR-E-2 Carrier Board Rev. 2 MR-E-2 CPU Board MR-E-2 Proxy Board MR-E-2 Carrier to Proxy Board cable USB cable Power supply
MR-E-2 Mirror head gold	MR-15-30-G-25x25D	Mirror head (incl. mirror and cable) Protection cap Heatsink
MR-E-2 Mirror head silver	MR-15-30-PS-25x25D	
MR-E-2 Mirror head DVIS	MR-15-30-DVIS-25x25D	
MR-E-2 Mirror head custom	MR-C-15-30 (custom mirror) or resonant mirror MR-10-30-G / MR-10-30-PS	

Safety and compliance

The product fulfills the RoHS, REACH, CE and flammability UV94 V-0 compliance standards. The customer is solely responsible for complying with all relevant safety regulations for integration and operation.

For more information on optical, mechanical, and electrical parameters, please contact sales@optotune.com