

MR-E-2 Development Kit (Rev. 2)

The MR-E-2 is a fully integrated driving solution for the Optotune MR-series 2D beam steering mirrors. It provides access to the full functionality of the mirrors, including open and closed loop control.



Main features:

- Graphic user interface *Optotune Cockpit* for control via USB
- Communication interfaces:
 - USB, UART
 - SPI
 - Analog input (± 5 V)
- Software SDKs for Python and C# available
- RoHS, REACH and CE certified

Mechanical specifications base unit

Dimensions (L x W x H)	116.0 x 84.6 x 34.6	mm
Weight	208	g
USB connector	Micro B	
Accepted DC Barrel Plug	2.1 I.D. x 5.5 O.D. x 10.0	mm

Mechanical specifications mirror head unit

Diameter	45	mm
Cable length	1	m
Height	31	mm
Weight	420	g

Electrical specifications

Supply voltage range	15 to 28	Vdc
Total power consumption (max)	12	W
SPI logic level (CMOS)	3.3	V

Thermal specifications

Storage temperature	-40 to +85	°C
Operating temperature	0 to 40	°C

Mirror specifications (see MR-15-30 datasheet)

Surface finish	Dielectric VIS, protected gold, protected silver, other coatings available on request	
Reflectivity (gold)	> 95% (800 nm – 6 μ m) at 45° AOI	
Reflectivity (silver)	> 96% (450 nm – 2 μ m) at 45° AOI	
Reflectivity (dielectric, DVIS)	> 97% (450 – 650 nm) at 45° \pm 25° AOI	
Mirror flatness (ISO 10110)	$\lambda/2$	
Mirror diameter	15	mm
Mechanical tilt angle DC	\pm 25 in every direction	°
Mechanical tilt angle dynamic	\pm 25 in every direction	°
Distance center of rotation to mirror surface	1.3	mm
Repeatability RMS (typical)	40	μ rad
Resolution (closed loop)	22	μ rad

Magnetic shielding	yes	
Full scale bandwidth, Sine wave ($\pm 25^\circ$)	20	Hz
Small signal bandwidth ($< \pm 0.1^\circ$)	350	Hz
Large angle step settling time (20° step)	13	ms
Small angle step settling time (0.1° step)	3	ms

Mirror specifications (MR-10-30 version)

Mechanical tilt angle DC	± 25 X axis; N/A Y axis	$^\circ$
Mechanical tilt angle dynamic	± 25 X axis; ± 12.5 Y axis	$^\circ$
Mirror diameter	10	mm
Weight	29.3	g
Full scale bandwidth, sine wave	20 for the static axis, approx. 280 for the resonant axis	Hz

Position feedback

Control loop frequency	10	kHz
Position readout jitter (via RTI)	± 5	ns
Position readout jitter (other interfaces)	± 50	μ s
Controller dead-time	0.4	ms

Overview of Available Standard Products

Standard Product	Mirror type included	Components included
MR-E-2 Base unit (Rev. 2)	N/A	MR-E-2 Base unit controller box (Rev. 2) Power supply USB cable
MR-E-2 Mirror head unit gold	MR-15-30-G-25x25D	Mirror head unit (incl. mirror and MR-E-2 Carrier to proxy board cable assembly) Protection cap Heatsink
MR-E-2 Mirror head unit silver	MR-15-30-PS-25x25D	
MR-E-2 Mirror head unit DVIS	MR-15-30-DVIS-25x25D	
MR-E-2 Mirror head unit custom	MR-C-15-30 (custom mirror) or resonant mirror MR-10-30-G / MR-10-30-PS	

Description and Features

Base Unit

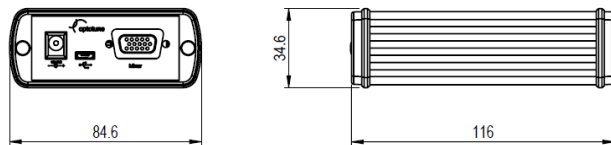

Pinout

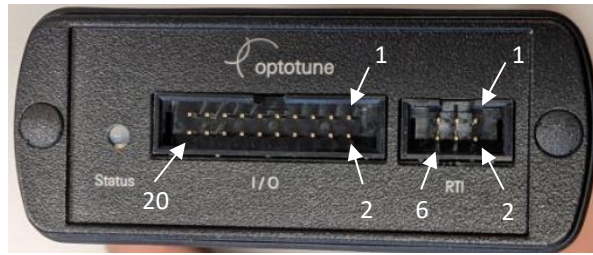

<i>Pin# on I/O Connector</i>	<i>Signal</i>	<i>Description</i>
1	UART_RX	UART Receive line
2	GND	Circuit ground
3	ERROR	Indicates an active error
4	UART_TX	UART Transmit line
5	-	Reserved
6	TRIGGER	Trigger input1
7	-	Reserved
8	STABILITY	Mirror not stable ²
9	-	Reserved
10	-	Reserved
11	GND	Circuit ground
12	SPI_DATA_NRDY	SPI Data Not Ready
13	SPI_NSS	SPI Negative Slave Select
14	SPI_MISO	SPI Master Input Slave Output
15	SPI_MOSI	SPI Master Output Slave Input
16	SPI_CLK	SPI Clock
17	GND	Circuit ground
18	GND	Circuit ground
19	AI_X	Analog Input X axis
20	AI_Y	Analog Input for Y axis

<i>Pin# on RTI Connector</i>	<i>Signal</i>	<i>Description</i>
1	-	Reserved
2	CS_SYNC	PD readout trigger (ADC chip select)
3	SCLK_LVDS	Clock
4	FSI	Frame start
5	MISO	Data line (one way only)
6	GND	Ground

¹ Trigger input for 3.3 V CMOS logics to synchronize signal generator or vector pattern unit with external signal.

² According to user defined stability criterion. See Firmware manual.

Mirror Head Unit

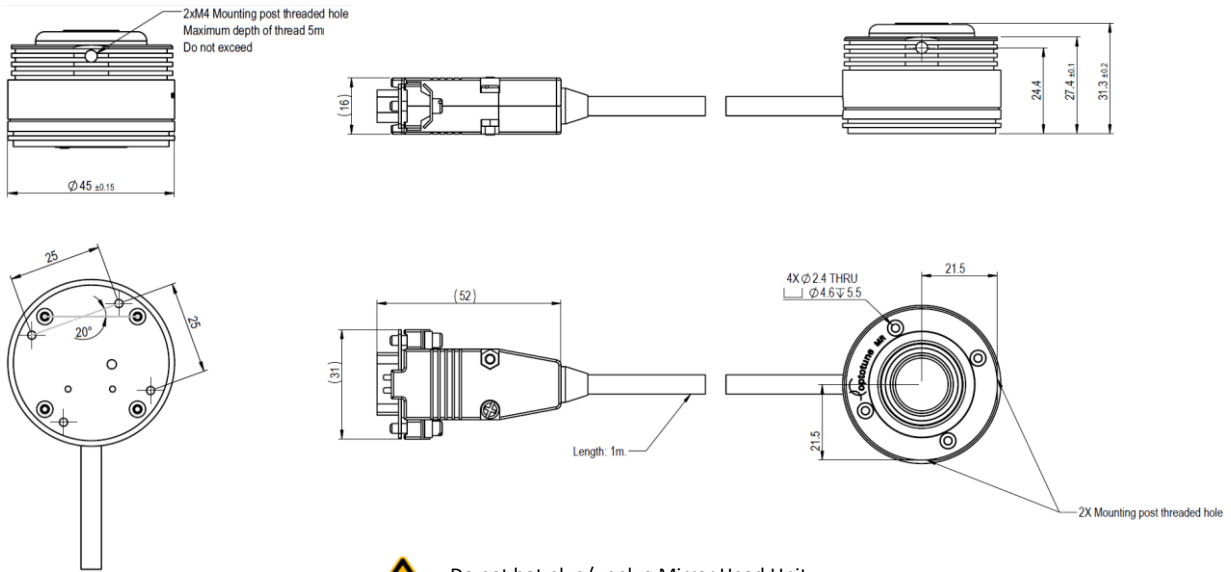

Do not hot plug/unplug Mirror Head Unit cable as permanent damage may result!

Mirror Head Unit with Heatsink

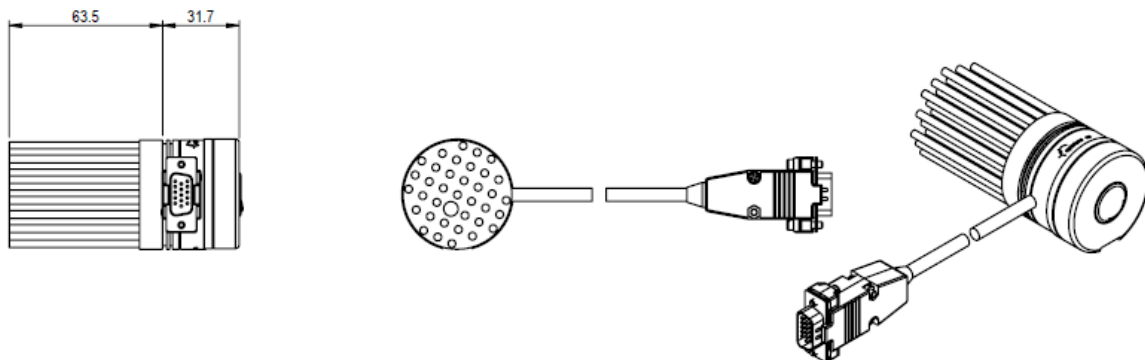

Thermal Management

MR-E-2 Mirror Head Unit main thermal features:

- Mirror (MR-15-30 or MR-10-30) and the analog driving electronics (Proxy Board) are thermally coupled
- Heat is generated as a function of actuation current (blue and green curves in Figure 1)
- Idling losses (yellow curve in Fig. 1) mostly occur in the Base unit
- Maximum dissipated power at max. static deflection is 2.25 W/channel (4.5 W total)
- For fast oscillations with high duty cycle the dissipated power is 10-15 W for the two axes combined
- Max. operating temperature is 85 °C
- For most applications the housing of the head unit provides enough heat sinking capacity and the provided heatsink is not required to be used

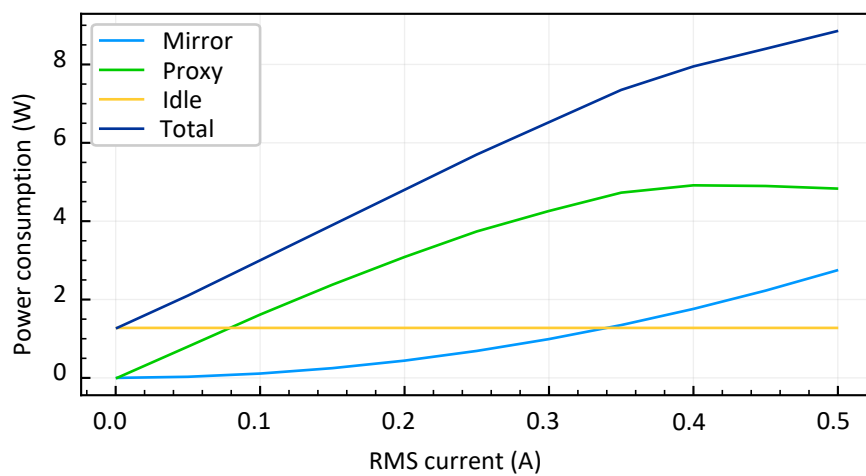

Figure 1: Power consumption for different parts of the device.

Safety and compliance

The product fulfills the RoHS, REACH, CE and flammability UV94 V-0 compliance standards. The customer is solely responsible for complying with all relevant safety regulations for integration and operation.

For more information on optical, mechanical, and electrical parameters, please contact sales@optotune.com