

MR-E-3 OEM Version

The MR-E-3 driver is the next-generation, fully integrated driving solution for the Optotune MR-series 2D fast steering mirrors. It provides access to the full functionality of the mirrors, including open and closed loop control, with an increased control bandwidth, reduced dead- and settling time, and efficient PWM driving compared to the previous-generation driver MR-E-2. Its OEM version is a modular solution that facilitates the integration of the MR-series mirror and driver into other systems.



Main features:

- Graphical user interface *Optotune Cockpit* for control via USB
- Communication interfaces:
 - USB, UART
 - SPI
 - Analog input (0 - 10V)
- Software SDKs for Python and C# available
- RoHS, REACH and CE certified

Included in the MR-E-3 OEM Version are the following parts:

- MR-E-3 Base unit board
- MR-E-3 Proxy board
- USB cable, Base unit to proxy board cable, Power supply

Mechanical specifications

Dimensions base unit board (L x W)	99.5 x 59.7	mm
Dimensions proxy board (L x W)	30 x 30	mm
Weight base unit board	45	g
Weight proxy board	8	g
USB connector	USB C	
Accepted DC barrel plug	2.1 I.D. x 5.5 O.D. x 10.0	mm
Cable length	1	m
Cable diameter	4.5	mm

Electrical specifications

Number of current output channels	2	
Supply voltage	24 ($\pm 10\%$)	V
Current source type	Class - D	
Continuous output current per channel	0.5	A
Continuous Power consumption (MR-15-30)	10	W
Peak output current per channel	1	A
Max. peak power consumption	35	W

DAC resolution	16	bit
DAC sampling rate	40	kHz

Position feedback

Control loop frequency	40	kHz
Sampling rate	160	kHz
Proxy SPI clock frequency	25	MHz
Position readout jitter	500	ns
Controller dead-time	100	µs
Analog input sampling rate (16 bit)	40	kHz

Environmental specifications

Operating temperature Base Unit	0 to +40	°C
Operating temperature Proxy Board	-20 to +85	°C
Storage temperature	-40 to +85	°C

Overview of available standard products

Standard Product	Mirror type included	Components included
MR-E-3 OEM Version	see below	MR-E-3 Base unit board Power supply USB cable
MR-series 2D mirror	One of the following: MR-15-30-G-25x25D MR-15-30-PS-25x25D MR-15-30-DVIS-25x25D MR-C-15-30 MR-10-30-G MR-10-30-PS	Mirror (incl. mirror and cable) MR-E-3 proxy board Base unit to proxy board cable

Mechanical layout

The mechanical drawings of the MR-E-3 base unit board and proxy board are shown in Figure 1 and Fig. 2, respectively. Optotune provides full schematics, manufacturing data and models for the base unit and proxy board on request. For further information, please contact sales@optotune.com.

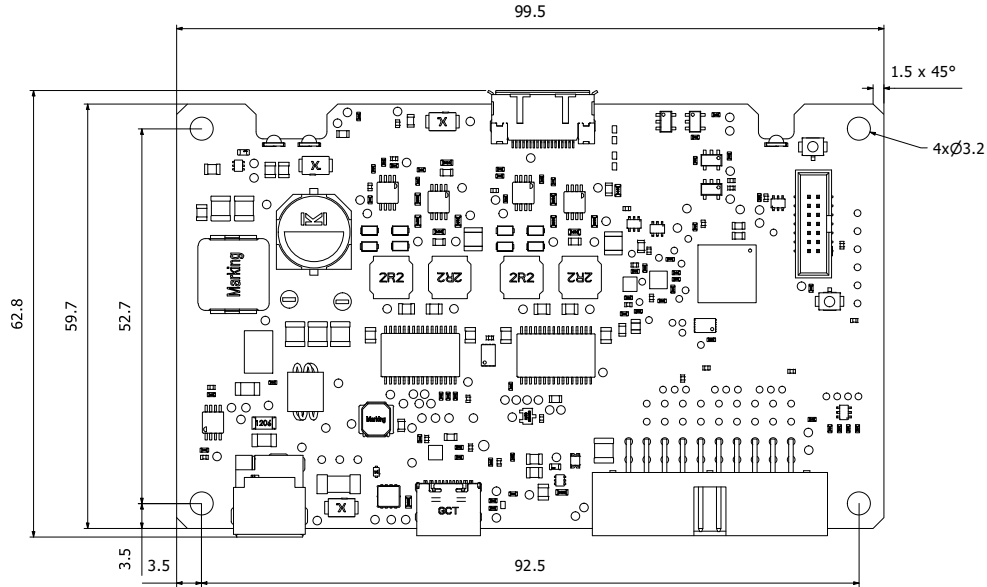

Figure 1: Mechanical drawing of the MR-E-3 base unit board (unit: mm).

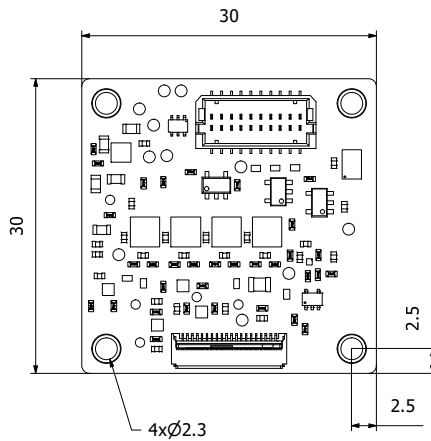

Figure 2: Mechanical drawing of the MR-E-3 proxy board (unit: mm).

For mechanical drawings of the MR-series 2D mirror, please refer to the corresponding datasheet.

Electrical layout

The connector block diagram of the modular parts of the MR-E-3 OEM version is shown in Fig. 3. Figure 4 illustrates the correct way of connecting the base unit board, proxy board, and MR-series 2D mirror.

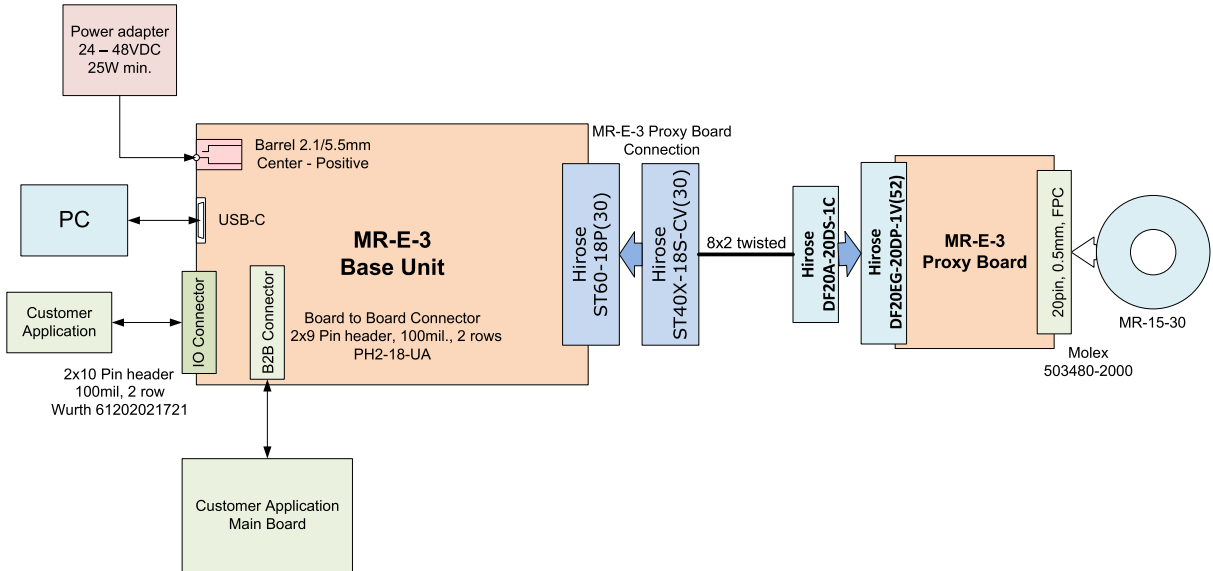

Figure 3: Connector block diagram for the MR-E-3 OEM version.

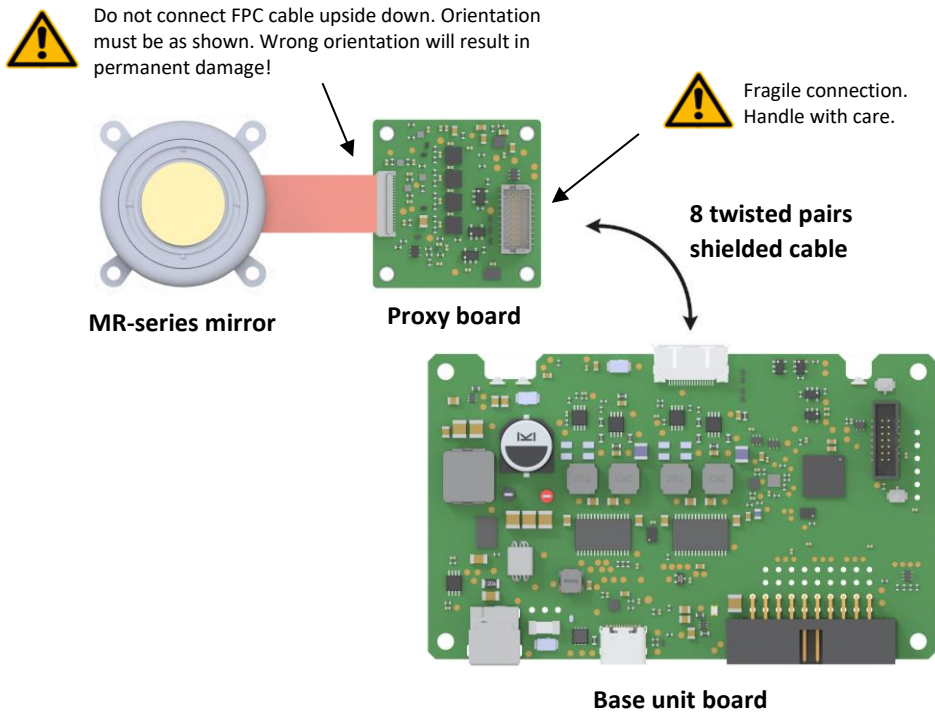
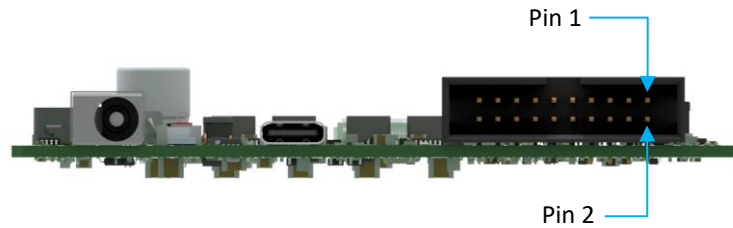

Figure 4: Schematics of correct mirror and board connection.



Pinout MR-E-3 base unit board		
Position	Function	Description
1	AI_X	Analog Input for X axis
2	AI_Y	Analog Input for Y axis
3	Signal GND	Digital and analog ground
4	External VCC Enable	Enable signal for external power supply (connect to GND to activate)
5	NRST	Reset signal for driver (connect to GND to activate)
6	SYNC_Y	Trigger Input/Output for Y axis*
7	UART TX/ I2C SCL	Serial interface transmitter line / I2C clock line**
8	SYNC_X	Trigger Input/Output for X axis*
9	UART RX/ I2C SDA	Serial interface receiver line / I2C data line**
10	SPI_DATA_NRDY	SPI Data Not Ready
11	Proxy SPI_CLK	Proxy Board SPI CLK output***
12	SPI_MOSI	SPI Master Output Slave Input
13	Proxy SPI_CS	Proxy Board SPI Chip Select output – conversion start signal
14	SPI_MISO	SPI Master Input Slave Output
15	Proxy SPI_MISO	Proxy Board SPI MOSI output ***
16	SPI_NSS	SPI Negative Slave Select
17	STABILITY	Mirror stable
18	SPI_CLK	SPI Clock
19	External VCC	External power supply input*
20	Power GND	Power GND of driver

* configurable input/output
 ** configurable external serial interface UART or I2C
 *** Proxy Board SPI digital output with raw data

Figure 5: Pin assignment of the MR-E-3 base unit board.

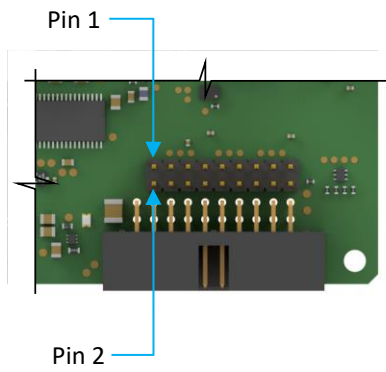

Pinout of board-to-board connector	
Position	Function
1	Proxy SPI_MISO
2	SPI_CLK
3	Proxy SPI_CS
4	SPI_NSS
5	Proxy SPI_CLK
6	SPI_MISO
7	GND
8	SPI_MOSI
9	SYNC_X
10	SPI_DATA_NRDY
11	SYNC_Y
12	GND
13	STABILITY
14	UART RX/ I2C SDA
15	NRST
16	UART TX/ I2C SCL
17	GND
18	GND

Figure 6: Pin assignment of the board-to-board connector.

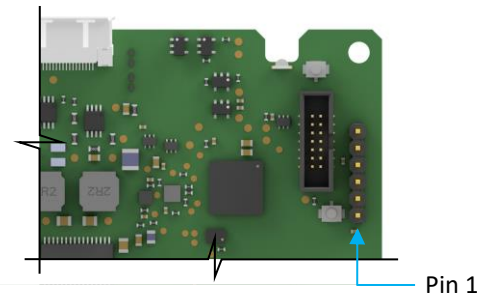

Pinout of programming connector	
Position	Function
1	MCU DEBUG Pin
2	BOOT
3	DEBUG - UART RX
4	DEBUG – UART TX
5	RESET
6	GND

Figure 7: Pin assignment for the programming connection.

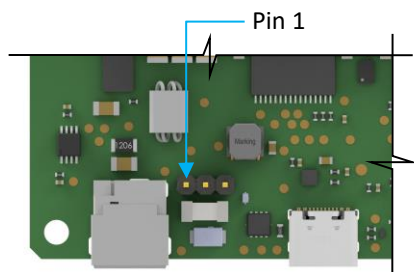

Pinout of external supply connector	
Position	Function
1	External VCC
2	External VCC Enable
3	GND

Figure 8: Pin assignment for the external supply connection.

Thermal management

Heat in mirror is generated as a function of actuation current flowing through the coils and is conducted away through the backside. MR-E-3 proxy board has very low power consumption compared to previous generation MR-E-2.

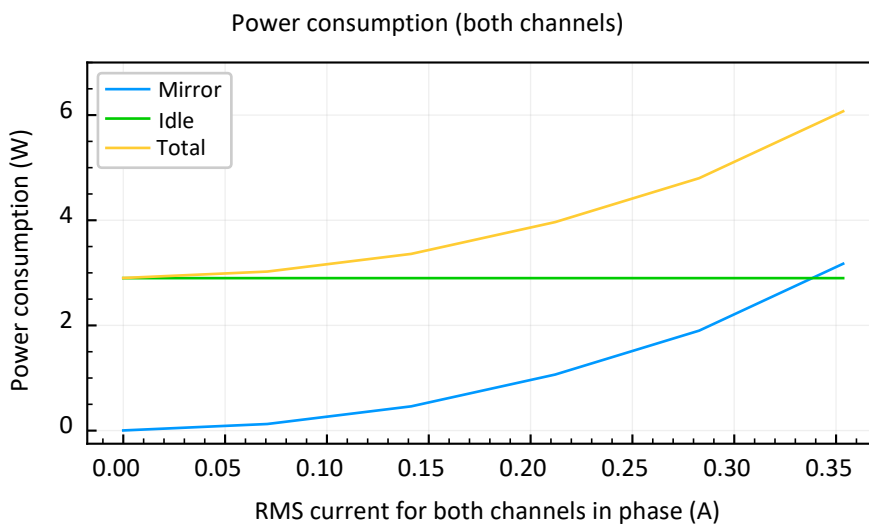

Figure 9: Power consumption dependencies.

Safety and compliance

The product fulfills the RoHS and REACH compliance standards. The customer is solely responsible for complying with all relevant safety regulations for integration and operation.

For more information on optical, mechanical, and electrical parameters, please contact sales@optotune.com.