

## Beam shifter BSW-20

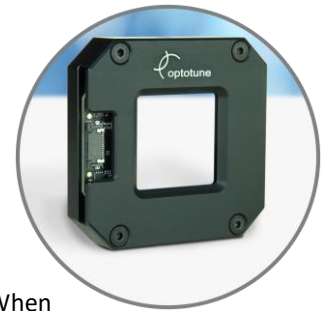

Optotune's beam shifter BSW-20 laterally displaces a beam by accurately tilting a glass window. The large clear aperture of 20 x 20 mm<sup>2</sup> makes the BSW-20 suitable for a variety of applications such as imaging, projectors, 3D printing or metrology. When used in imaging, the combination of multiple shifted images can yield super-resolution beyond the pixel limit. Together with the Optotune ICC-4C-2000, the BSW-20 is a plug-and-play solution for beam shifting.

### Main features:

- Fast transition times
- Linear relationship between current and angle
- Bearingless design – no particles generated, no wear, no friction
- Supports beam shifts of up to 4.8 μm

Tailoring to specific geometrical, actuation, and optical requirements is possible upon request.

### Mechanical specifications

Actuator type	Voice coil	
Mechanical tilt angle, single axis <sup>1</sup>	±5.2 ±0.3	mrاد °
Mechanical tilt angle, simultaneous actuation of both axes <sup>1</sup>	±3.5 ±0.2	mrاد ° Circular field of view
Max. beam shift	4.8	μm (peak-to-peak)
Clear aperture	20 x 20	mm
Window thickness	2	mm
Device dimensions (width x height x depth)	50.8 x 50.8 x 12	mm
Weight	53	g

### Performance specifications

Motion pattern	2D programmable	
Position control	Open loop	
External sensor for feedback control	Can be added	
Scale drift	1000	ppm/K
Resolution (with ICC-4C-2000)	4	μrad
Static motor constant	17.5 1.0	mrاد/A °/A
Dynamic motor constant	1.2 · 10 <sup>4</sup>	rad/(As <sup>2</sup> )
Resonance frequency	130 ± 5	Hz
Bandwidth (sine wave, ± 2.3 mrاد)	250	Hz

<sup>1</sup> Higher mechanical tilt angles of up to ±0.4° can be reached, limited by mechanical tolerances. Please note that there is a risk of damaging the device at deflections larger than ±0.3°, as well as increased noise and reduced overall performance. If you would like to operate the BSW-20 at such deflections, please contact [sales@optotune.com](mailto:sales@optotune.com).

Typ. transition (rise) time <sup>2</sup>	1.3	ms
Settling time <sup>2</sup>	4	ms

## Optical specifications

Window material and finish	B 270, VIS-coated <sup>3</sup>	
Refractive index	1.523	
Abbe number	58.5	
Transmission VIS-coated	>98% at 400-680 nm	0-34° AOI
Surface quality	5/ 5x0.2; L1x0.04; C3x0.2	ISO norm 10110, equivalent to scratch-dig 60/40
Transmitted waveform error	13/ -(-) RMSi < 80	nm

## Electrical specifications

Max. continuous current (RMS)	single axis: 300 both axes: 200	mA, per channel
Max. peak current (10 ms duration)	1	A
Power consumption (average)	< 2	W
Nominal actuator resistance per channel	9.8	Ω
Temperature sensor	ILM75BTP,147 or compatible	I2C-address: 1001100x (R: 0x98 / W: 0x99)
EEPROM	M24C64-FMC6TG or compatible	I2X-address: 1010000x (R: 0xA0 / W: 0xA1)

## Overview of available standard products

Standard Product	Version	Coating
BSW-20-4.8-VIS-M	Mounted in housing	VIS (400-650 nm)
BSW-20-4.8-VIS	Unmounted	VIS (400-650 nm)

## Control

The BSW-20 is controlled with Optotune's ICC-4C-2000 industrial 4-channel controller, together with the ICC-4C-2000 extension kit (adapter board). One ICC-4C-2000 has four output channels and supports two BSW-20 devices. See separate datasheet for more information.

For the device control, please install the latest software and firmware from our [website](#):

- Optotune Cockpit (GUI)
- ICC-4C-2000 Firmware
- ICC-4C SDK in Python or C#

For optimized operation with arbitrary trajectories, a smart filter for the input signal is available in a function called SmartStep. For access to SmartStep, either within Optotune Cockpit or as part of the Python SDK, please contact [sales@optotune.com](mailto:sales@optotune.com).

<sup>2</sup> The transition time is the time it takes from one setpoint to the next, within a 12.5% margin. The shortest transition times are reached with an optimized current input, available on the ICC-4C-2000. The settling time can be as small as three times the transition time. The transition time depends only moderately on the step size, here given for 3.5 mrad (half range).

<sup>3</sup> Custom window materials and coatings available upon request.

## Working principle

The BSW-20 works by laterally shifting an incoming beam. The shift is performed by tilting a planar glass window through which the impinging beam is passing. The relation between the tilt angle  $\theta$  and the resulting beam displacement  $\Delta y$  is shown in Fig. 1. Here,  $t$  denotes the thickness of the glass plate and  $n$  its refractive index.

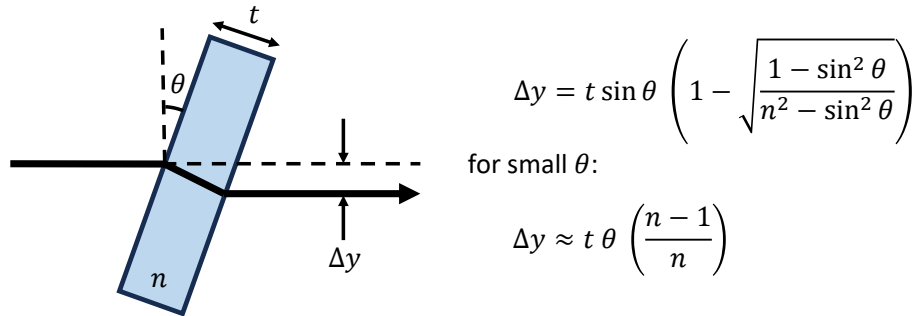

Figure 1: The BSW-20 actuator principle. Tilting a glass window an angle  $\theta$  results in a lateral beam shift  $\Delta y$ . For small angles, the expression for  $\Delta y$  can be simplified.

The BSW-20 can tilt a glass window along two axes to reach four distinct positions – so-called 4-position (4P) beam shifting. The principle is illustrated in Fig. 2. As a result, each pixel is projected at four locations, quadrupling the resolution (increasing the resolution by up to a factor of two in each lateral direction). Note that even with beam shifting, the resolution will ultimately be limited by the diffraction limit.

The driving pattern can be of arbitrary shape, not limited to a square, and patterns with fewer and more positions are possible.

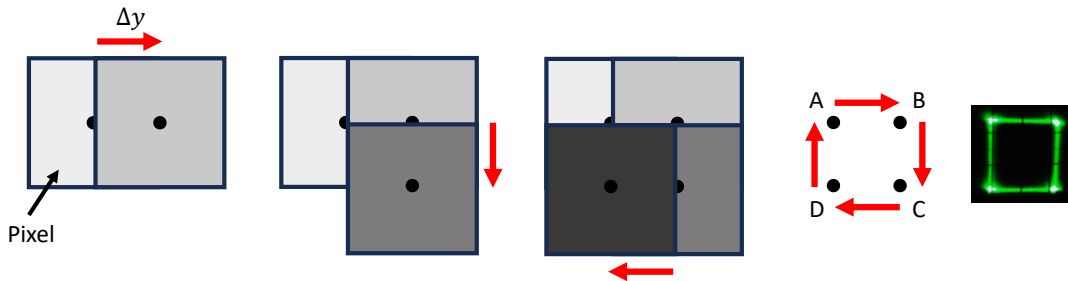

Figure 2: 4-position (4P) beam shifting. Each pixel is projected at four locations A, B, C and D, resulting in an up to four-fold increase in the native resolution. The rightmost image shows the effect on a laser beam, with the four corners of the square corresponding to the four positions of the BSW-20.

For more information on how the BSW-20 can be used to achieve super-resolution in imaging, please refer to the corresponding [application note](#).

## Mechanical layout

The BSW-20 is offered in two configurations – mounted in a housing, and unmounted. The mechanical layout of the BSW-20 in a housing (product name BSW-20-4.8-VIS-M) is illustrated in Fig. 3. The housing supports mounting on standard optical posts (M4).

The mounted version of the BSW-20 facilitates plug-and-play operation of the device.

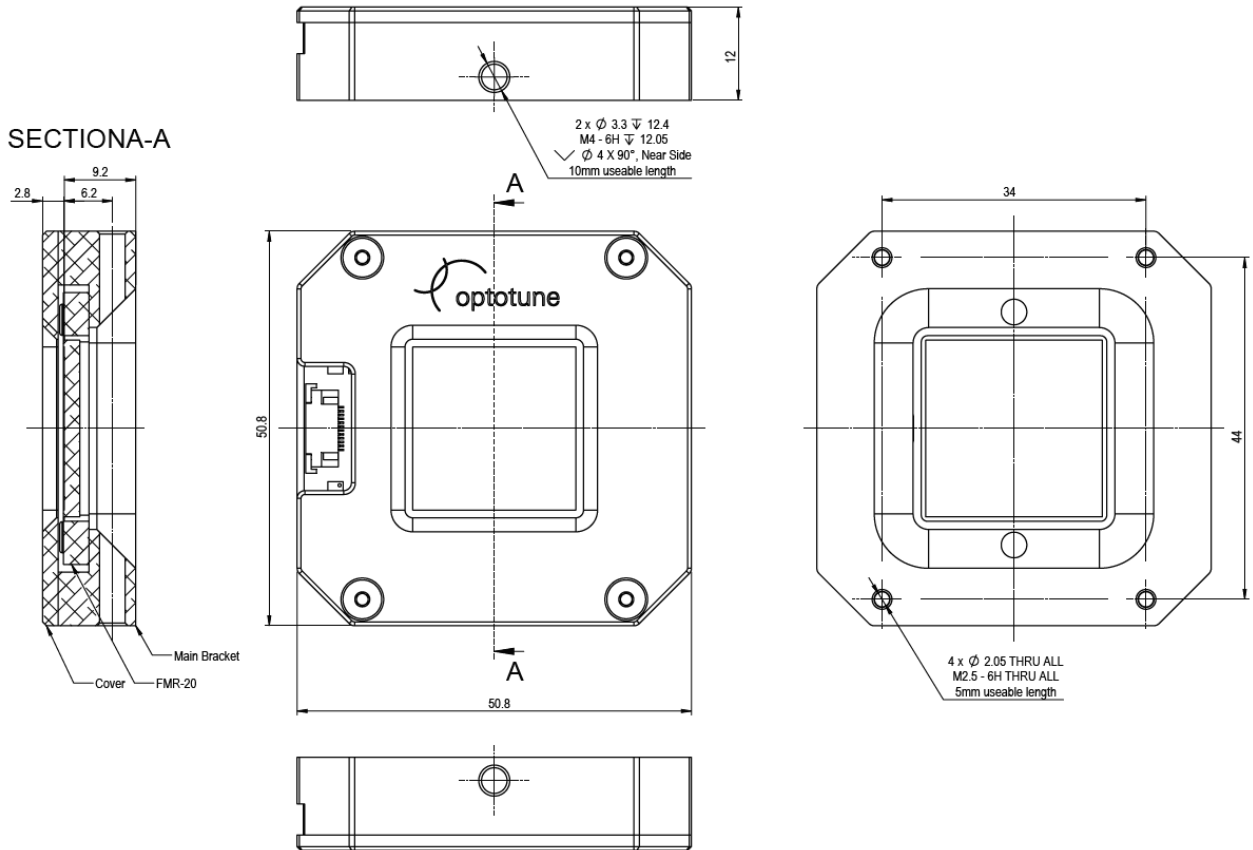

Figure 3: Mechanical drawing of the BSW-20 mounted in a housing. Units: mm.

The housing of the BSW-20 is compatible with the kinematic mount #58-861 from Edmund Optics (not included), shown in Fig. 4. This tip-tilt stage allows to do a manual angular coarse adjustment. The item is to be purchased directly from Edmund Optics.

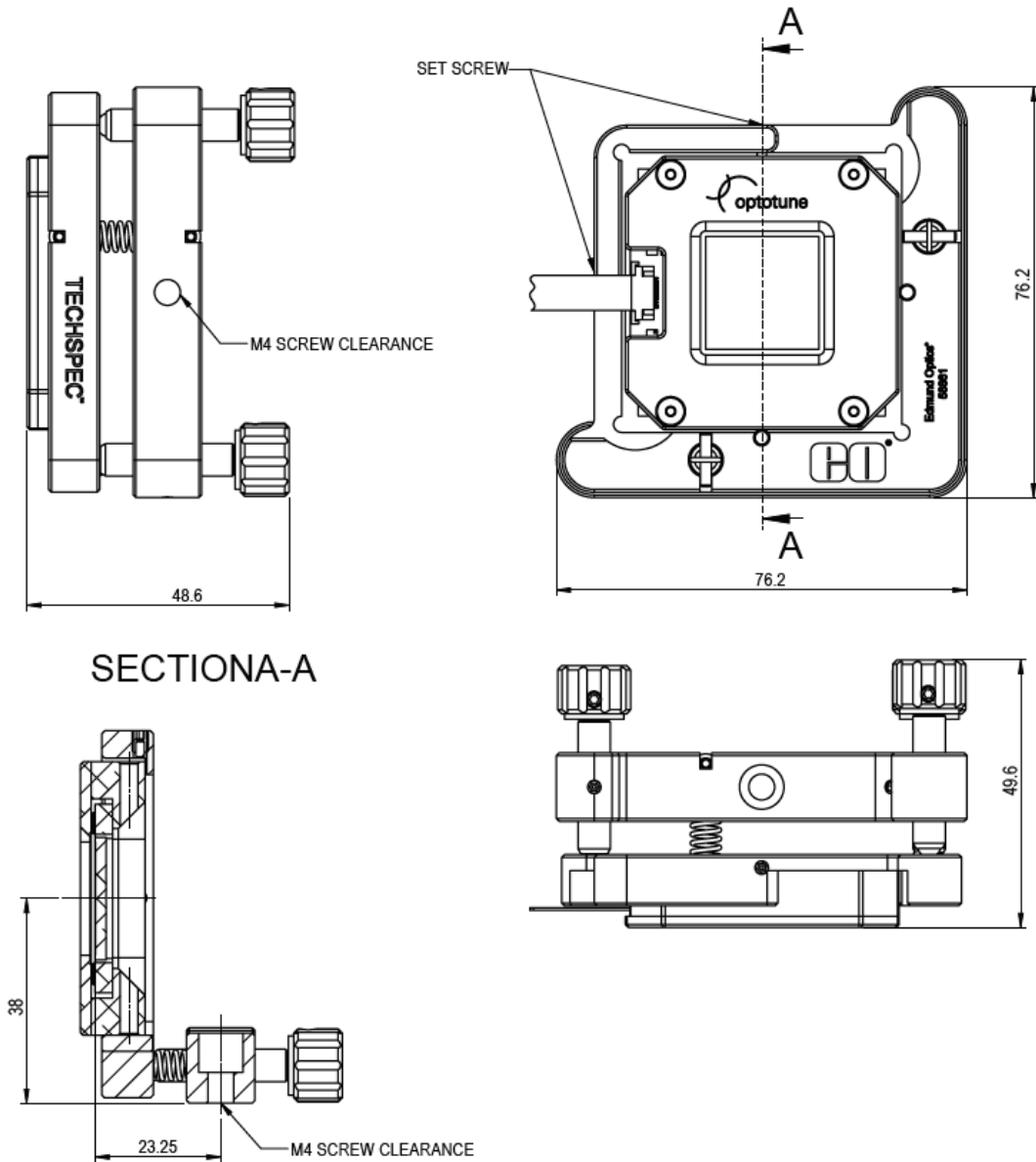

Figure 4: Compatible kinematic mount for the BSW-20.

The mechanical layout of the BSW-20 without the housing (product name BSW-20-4.8-VIS) is illustrated in Fig. 5. For more details on this configuration, please contact Optotune.

The unmounted version of the BSW-20 simplifies the integration of the device into other systems.

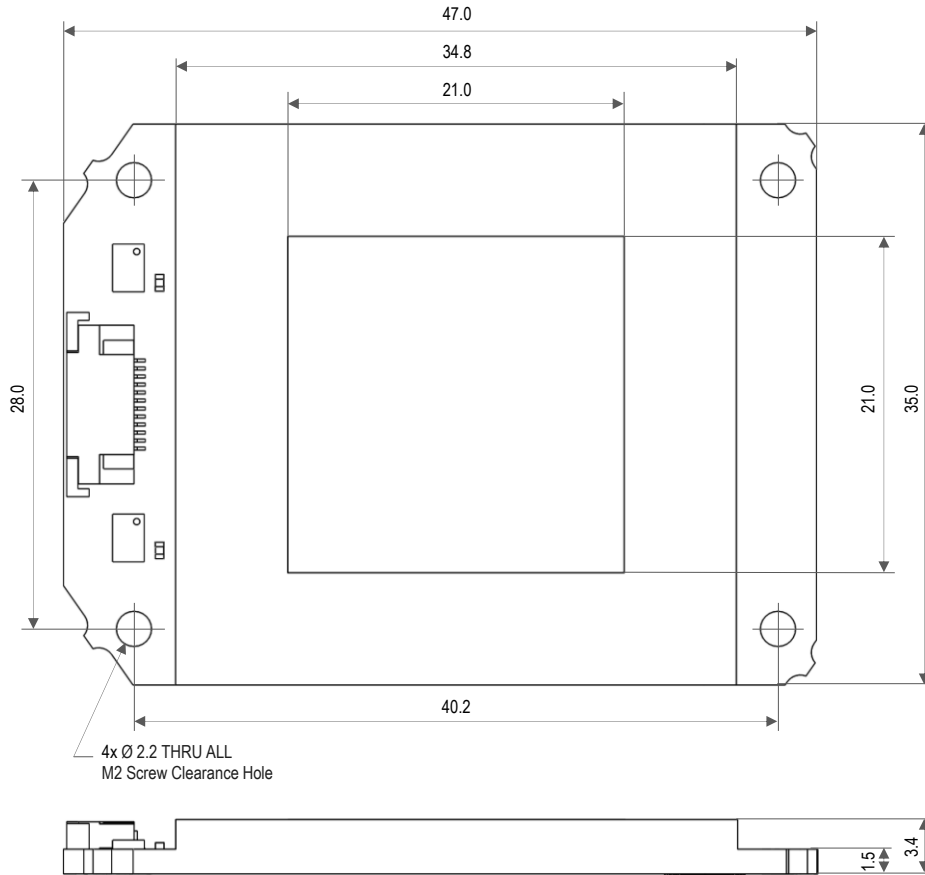

Figure 5: Mechanical drawing of the unmounted BSW-20. Units: mm.

## Electrical layout

The BSW-20 connection is a standard FFC cable (Molex 12 pin, 0.5 mm pitch). The cable can be plugged directly into the connector of the adaptor board, following Fig. 6: open the connector clamp with tweezers, insert the flex cable fully with the copper pads facing upwards, and close the black clamp by pushing both sides simultaneously.

**IMPORTANT:** Do NOT hotplug the flex cable from the device!

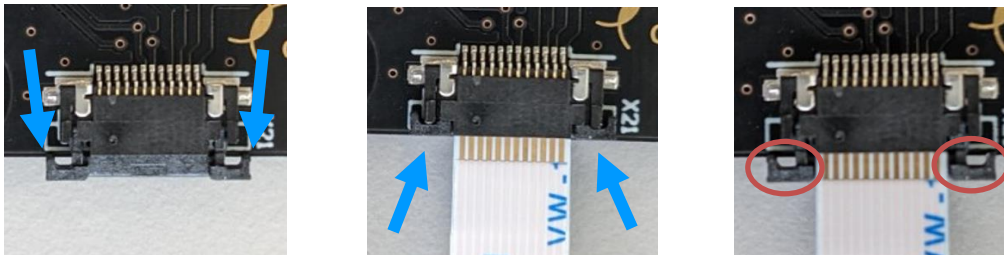
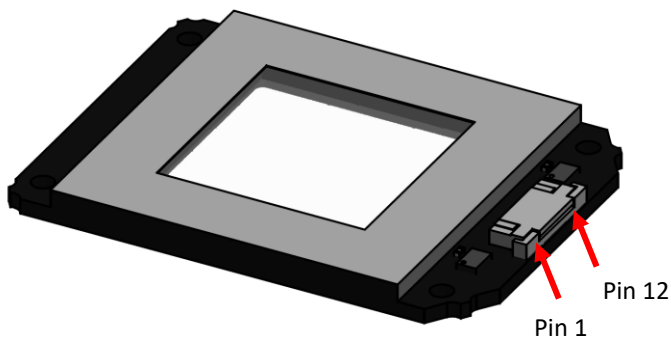

Figure 6: FFC cable connection. From left to right: open the connector clamp, indicated by blue arrows; insert the cable and close the connector clamp; connection cannot be guaranteed if the clamp is still open.

The pinout of the BSW-20 is shown in Fig. 7.



Pinout: BSW-20		
Position	Function	Value
1	Axis X+	0-300 mA
2	Axis X-	0-300 mA
3	Axis Y+	0-300 mA
4	Axis Y-	0-300 mA
5	Vcc	3.3 V
6	I <sup>2</sup> C SDA	Digital signal
7	I <sup>2</sup> C SCL	Digital signal
8	GND	-
9	N.C.	-
10	N.C.	-
11	N.C.	-
12	N.C.	-

Figure 7: Pin assignment of the BSW-20. RMS values are stated for the X/Y axis current control.

## Transmission

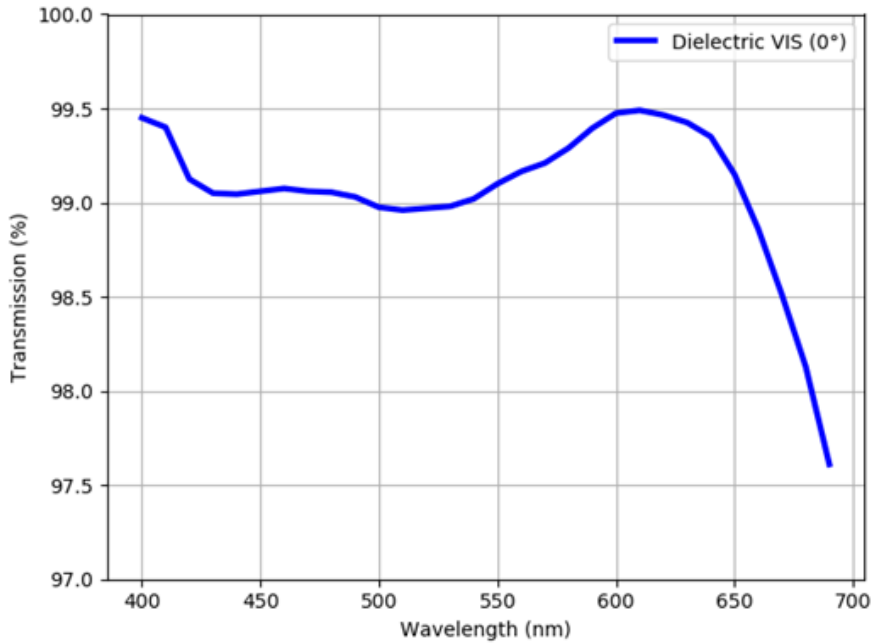

Figure 8: Transmission spectrum of standard window. For NIR/UV applications, both the material and the coating of the window can be customized.

## Static response

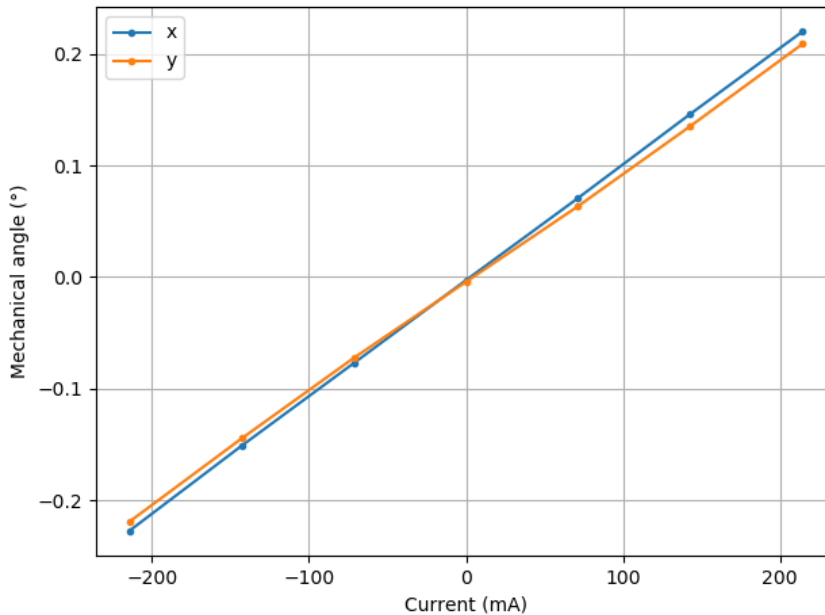

Figure 9: Typical static response as a function of current for the two axes of the BSW-20.



## Frequency response

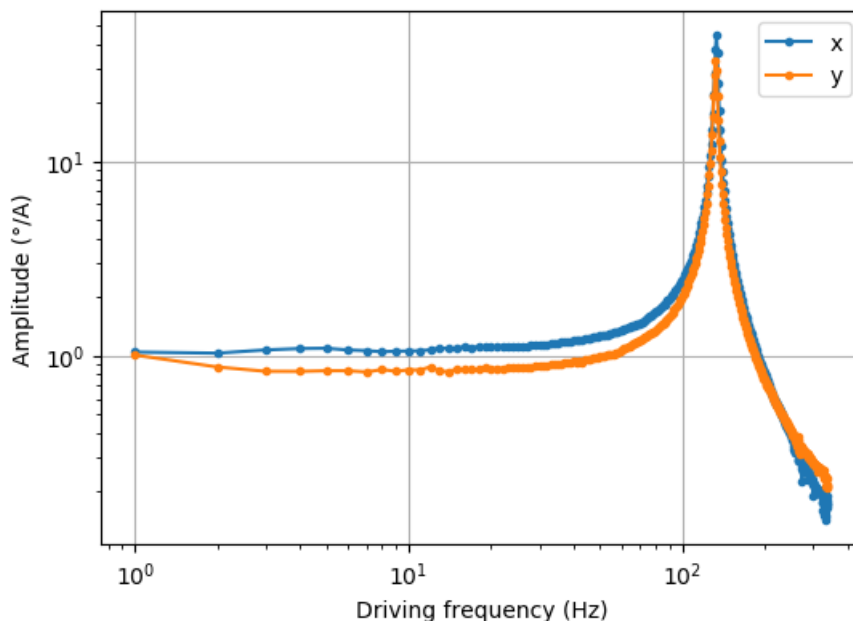

Figure 10: Typical frequency response for the two axes. The resonance frequencies for x and y are at 132 Hz and 133 Hz, respectively.

## Step response

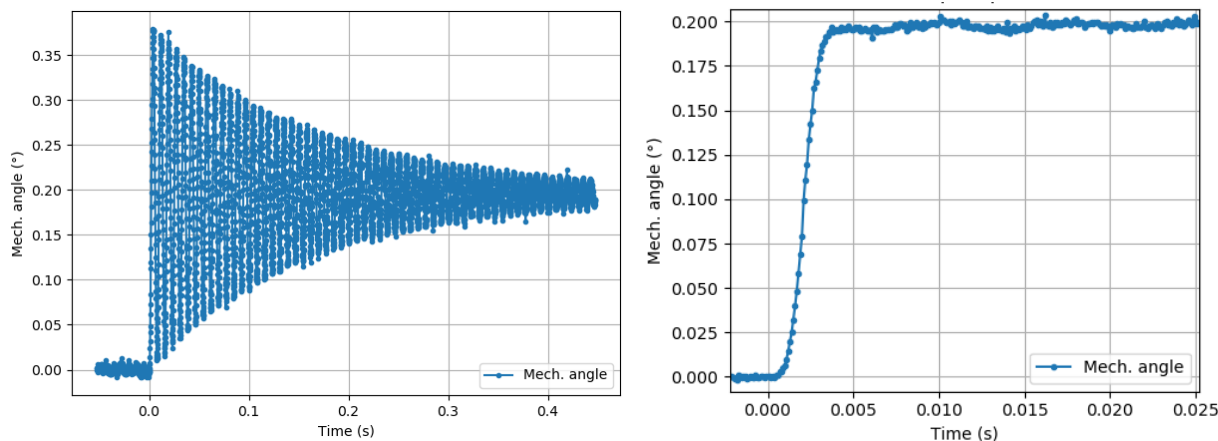

Figure 11: Step response of the BSW-20 with a sharp current step input (left) and optimized current input (right). Exciting the resonance can be avoided by filtering the input (available on the ICC-4C-2000 controller), which reduces the step response time from about 1 s to about 4 ms.

## Safety and compliance

The product fulfills the RoHS, REACH, CE and UL94 V-0 compliance standards. The customer is solely responsible for complying with all relevant safety regulations for integration and operation.

For more information on optical, mechanical, and electrical parameters, please contact [sales@optotune.com](mailto:sales@optotune.com).